



Class weather station

Weather

time

95 minutes

learning outcomes

To:

- know that a thermometer works using liquid that expands or shrinks
- know that the temperature of the air affects humidity
- know that we use the Beaufort wind force scale to express the speed of the wind
- be able to record results in a table
- be able to interpret results from a table
- research weather conditions on other planets in the solar system

end product

- three weather instruments: a thermometer, a hygrometer, and an anemometer
- a weather journal

materials needed

- 8 thermometers
- 2 plastic bottles
- 2 clear drinking straws
- 2 gauze dressings
- 2 elastic bands
- 2 drawing compasses
- 2 long wooden skewers
- 2 table tennis balls
- card
- scissors
- liquid food colouring
- cold water
- modelling clay or plasticine
- felt-tip pens
- rulers
- sticky tape
- sewing thread
- books or computers with internet
- sunlight
- refrigerator

Preparation

For the activity **What is the weather today** (thermometer), look up today's weather forecast. Prepare the materials for the different groups. For the activity **Making a Weather Station** (thermometer) you will need a jug of water with a few drops of food colouring. For the activity **Information exchange** you will need to draw a table on the board in which the children can record the weather.



What is the weather today? 5 min.

Explain to the children that they are going to build a weather station together. Organise the children into groups of four. Two groups will make a thermometer, two groups a hygrometer, and two groups an anemometer. Explain that each child in the group has a specific task. This is shown on the worksheet. Each worksheet has its own exploratory exercise. The children complete Task 1 on the worksheet.



The following questions are investigated: How does a thermometer work? What is the humidity today? Did today's weather forecast make an accurate prediction of the wind speed?



Making a weather station 45 min.

The children complete Task 2 on the worksheet. For the thermometer, explain that liquids expand when they heat up.



Information exchange 20 min.

The children tell each other what they have made and explain how their instrument works. Encourage the children to find a suitable place in the classroom for their instrument. The children record the results of their measurements in the table on the board.



The weather journal 20 min.

The children have recorded the weather for a whole week. Explain that each group is going to make a weather journal about their instrument.

The weather journal will contain an overview of the temperature, humidity and wind force from the past week. The children complete Task 3 on the worksheet. They should write about the following subjects:

Thermometer: how the thermometer works, and temperatures on other planets in our solar system. Which planet is the coldest, and which the hottest? Does this have anything to do with the planet's distance from the Sun?

Hygrometer: how the hygrometer works, and humidity on other planets in our solar system. Which planet is the most humid, and which the least? Does the humidity have anything to do with the planet's distance from the Sun? Why is there no liquid water on the other planets?

Anemometer: how the anemometer works, and wind on other planets. Which planet has the most powerful winds and which the least powerful?

Encourage the groups to share their weather journal information. Organise the children into groups of three. Each group will have a temperature expert, a wind expert, and a humidity expert. The children explain to each other what they found out in their group about how their instrument works and the measurements they took. The children use this information to make a group weather forecast for the coming week. This will give you eight forecasts per class. Copy these forecasts, together with the weather report for the previous week, and give them to the children to take home.

Good to know.

Liquids expand as they get hotter, because the molecules move around faster. This makes them take up more space.



Class weather station

1 What is the weather today?

a Look at today's weather forecast.



What is the forecast for the temperature?

b What do we use to measure temperature?



In this experiment you will be answering the research question:

How does a thermometer work?

c What do you think is the answer to this question?



A thermometer works by:

2 Make a weather station

Everyone has a specific task in helping to make this thermometer.



See 'What do you need to do?' on the following page.

Decide together who will carry out which task.

What do you need?

- card
- clear drinking
- outdoor
- scissors
- modelling clay
- thermometer
- plastic bottle
- or plasticine
- fridge
- liquid food colouring
- felt-tip pens
- sunlight or
- cold water
- ruler
- radiator

What do you need to do?

Child 1

1 Use the ruler to measure a 5 x 5 cm square on the card.

Cut out this square.

2 Cut two parallel slits in the card and thread it onto the straw, as shown in the drawing at the bottom of the page.

Child 2

3 Fill the bottle with coloured water, right to the brim.

Child 3

4 Put the straw in the bottle.

5 If you suck on the straw, the liquid in the bottle will rise through the straw. Suck very carefully on the straw until the liquid appears between the slits in the card (see drawing). Quickly cover the top of the straw with your finger so that the liquid stays in the straw.

Child 4

6 Use the modelling clay to secure the straw in the bottle. Make sure the mouth of the bottle around the straw is completely sealed, so the liquid stays in the straw. Look at the drawing to see how to do this. Your thermometer is ready!

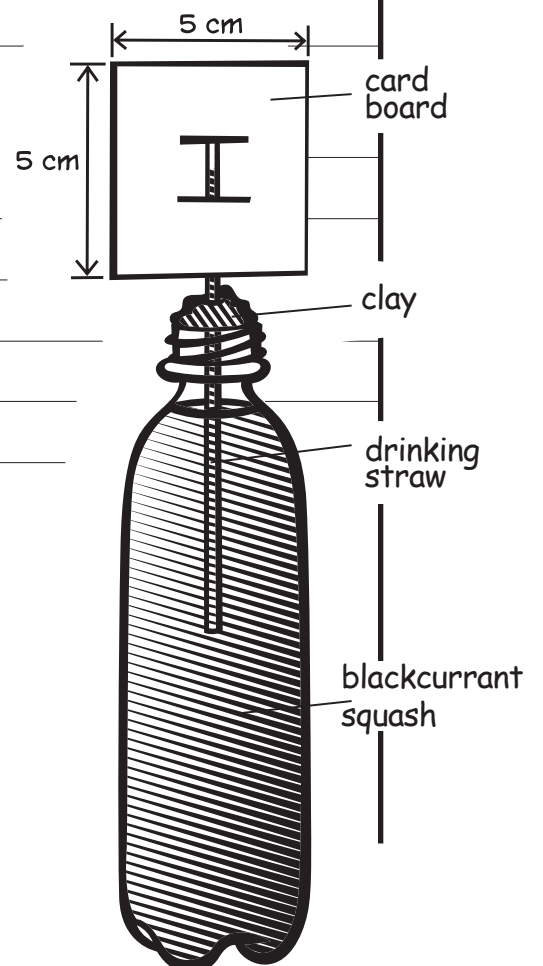

7 Place the thermometer on a sunny windowsill or near the radiator.

a What happens?



b Circle your answer

When the temperature increases, the liquid in the straw

rises / falls

CIRCLE the correct answer

8 Put your thermometer in a shady spot or in the fridge.

c What happens?

d Circle your answer.

When the temperature falls, the liquid in the straw

rises / falls

CIRCLE the correct answer

e Why is it that the level of liquid moves when the thermometer gets hotter or colder?

f Now answer the research question: *How does a thermometer work?*

g

Is your answer the same as you wrote in Question 1c? If not, what have you learned?

3

The weather journal



You are going to make a page about the thermometer for the weather journal.

For this you will need to answer the following questions.

Use books or the internet to find any extra information you need.

How does the thermometer work?

- What are the temperatures on other planets in our solar system?

- Which planet is the coldest, and which the hottest?

- Does this have anything to do with the planet's distance from the Sun?



Class weather station

1 What is the weather today?

a What do you think a hygrometer is used for?



In this experiment you will be answering the research question:

What is the humidity today?

b Do you think the air is very humid today or not?



2 Make a weather station



Everyone has a specific task in helping to make this hygrometer.

What do you need to do? Decide together who will carry out which task.

What do you need?

- 2 thermometers
- piece of card measuring 20 x 15 centimetres
- sticky tape
- gauze dressing
- elastic band
- water

What do you need to do?

Child 1

- 1 Place a thermometer near the edge of the card, as shown in the drawing at the bottom of the page. Make sure the 20° Celsius mark on the thermometer is lined up with the bottom edge of the card.
- 2 Attach the thermometer to the card using sticky tape.

Child 2

- 3 Place the other thermometer near the opposite edge of the card. Make sure the 20° Celsius mark on this thermometer is also lined up with the bottom edge of the card.
- 4 Attach the thermometer to the card using sticky tape.

Child 3

- 5 Take the gauze dressing and soak it in water.
- 6 Wrap it around the bottom of the left-hand thermometer so that the bulb of the thermometer is completely covered.

Child 4

- 7 Attach the gauze dressing to the thermometer using the elastic band. Your hygrometer is ready!

- 8 Wave the card in the air carefully for 2 seconds.

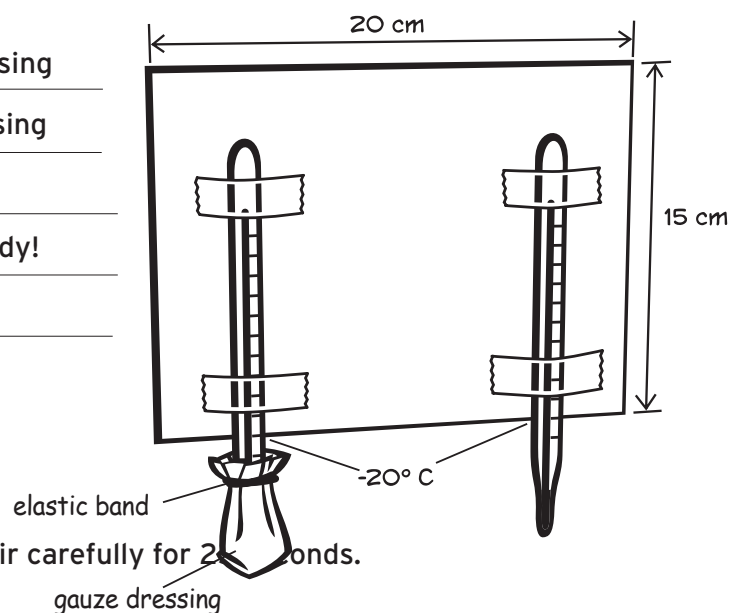

a What temperature does the left-hand thermometer show?

degrees



What temperature does the right-hand thermometer show?

degrees

What is the difference in temperature between the two thermometers?

degrees

b ~~Use the table below to look up the relative humidity of the air today~~

c Circle your answer.

look up the temperature of the right-hand thermometer **HERE**

		Difference between dry and wet												
Dry bulb temp.		0.5	1	2	3	4	5	6	7	8	9	10	11	12
1	91	83	0	0	0	0	0	0	0	0	0	0	0	0
2	92	84	68	0	0	0	0	0	0	0	0	0	0	0
3	92	84	69	54	0	0	0	0	0	0	0	0	0	0
4	92	85	70	56	42	0	0	0	0	0	0	0	0	0
5	93	86	72	58	45	32	0	0	0	0	0	0	0	0
6	93	86	73	60	47	35	23	0	0	0	0	0	0	0
7	93	87	74	61	49	37	26	14	0	0	0	0	0	0
8	94	87	75	63	51	40	29	18	7	0	0	0	0	0
9	94	88	76	64	53	42	31	21	11	1	0	0	0	0
10	94	88	77	65	54	44	34	24	14	5	0	0	0	0
11	94	88	77	66	56	46	36	26	17	8	0	0	0	0
12	94	89	78	68	57	48	38	29	20	11	3	0	0	0
13	95	98	79	69	59	49	40	31	23	14	6	0	0	0
14	95	90	79	70	60	51	42	33	25	17	9	2	0	0
15	95	90	80	71	61	52	44	36	27	20	12	5	0	0
16	95	90	81	71	62	54	46	37	30	22	15	8	1	0
17	95	90	81	72	64	55	47	39	32	24	17	10	4	0
18	95	91	82	73	65	56	49	41	34	27	20	13	7	0
19	95	91	82	74	65	58	50	43	35	29	22	15	9	0
20	96	91	83	74	66	59	51	44	37	30	24	18	12	0
21	96	91	83	75	67	60	52	46	39	32	26	20	14	0
22	96	92	83	76	68	61	54	47	40	34	28	22	16	0
23	96	92	84	76	69	62	55	48	42	36	30	24	18	0
24	96	92	84	77	69	62	56	49	43	37	31	26	21	0
25	96	92	84	77	70	63	57	50	44	38	33	27	22	0
26	96	92	85	78	71	64	58	51	46	40	34	29	24	0
27	96	92	85	78	71	65	59	52	47	41	36	30	25	0
28	96	93	85	79	72	65	59	53	48	42	37	32	27	0
29	96	93	86	79	72	66	60	54	49	43	38	33	28	0
30	96	93	86	79	73	67	61	55	50	44	39	34	30	0
31	96	93	86	80	73	67	62	56	51	45	41	36	31	0
32	97	93	86	80	74	68	62	57	52	46	42	37	32	0
33	97	93	87	80	74	69	63	58	52	47	43	38	34	0
34	97	93	87	81	75	69	64	58	53	48	44	39	35	0
35	97	93	87	81	75	70	64	59	54	49	44	40	36	0

look up the difference between the two thermometers **HERE**

The higher the figure from the hygrometer, the more

humid / dry the air is.

CIRCLE
the correct
answer

d Now answer the research question: *What is the humidity today?*

If the humidity is under 50, this means it is low humidity. A measurement between 50 and 60 means moderate humidity. If the humidity is over 60, this means the air is very humid.

e So the humidity today is
low / moderate / high

CIRCLE
the correct
answer

Is your answer the same as you wrote in Question 1b?

3 The weather journal

You are going to make a page about the hygrometer for the weather journal.



For this you will need to answer the following questions.

Use books or internet to find any extra information you need.

- How does a hygrometer work?
- What is the humidity on other planets in our solar system?
- Is the humidity less if the planet is further from the Sun?



Class weather station

1 What is the weather today?

a What do you use an anemometer for?



In this experiment you will be answering the research question:

What is the wind speed today?

b Look out of the window Is it windy? How would you describe the wind today?



2 Make a weather station



Everyone has a specific task in helping to make this anemometer.

What do you need to do? Decide together who will carry out which task.

What do you need?

- piece of card measuring 25 x 15 centimetres
- drawing compass
- long wooden skewer
- sticky tape
- strong, thin string
- scissors
- ruler
- a table tennis ball
- pencil

What do you need to do?

Child 1

1 Set the points of the compass to a distance of 10 centimetres.

2 Draw a semicircle on the card as shown in the drawing.

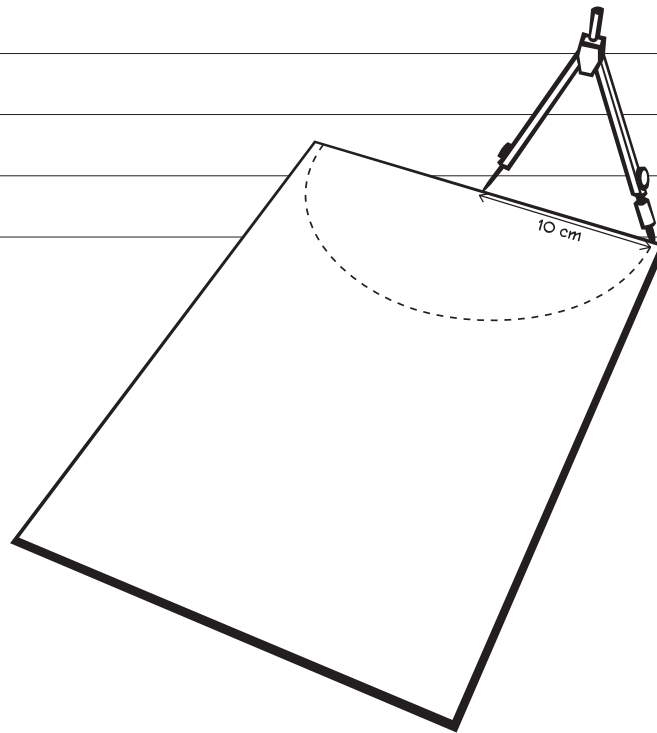

3 This semicircle has a radius of 10 centimetres. Cut out the semicircle.

4 Use the scissors to make an upright cut 5 millimetres long in the middle of the straight side.

Child 2

5 Cut a piece of thread around 20 centimetres long.

Pull one end of the thread 2 centimetres through the cut in the card.

6 Attach the thread to the back of the card using sticky tape.

7 Attach the other end of the thread to the table tennis ball using sticky tape.

Child 3

8 Divide the semicircle into 18 segments using a pencil. Start by dividing the semicircle in half. Then divide each quarter circle into three equal segments, and divide these segments into three. You will now have 18 segments all the same size.

9 Place the semicircle on the table with the straight side at the top. Write the number 90 next to the line in the middle. Working from the middle towards the right-hand side of the semicircle write the following numbers next to each line, as shown in the drawing below: 80, 70, 60, 50, 40, 30, 20, 10.

Child 4

10 You are going to write the numbers on the left-hand side. Next to the following empty lines after the middle 90 line: write the numbers 80, 70, 60, 50, 40, 30, 20, 10. Attach the wooden skewer to the back of the semicircle along the middle line using sticky tape, so that half of it is sticking out from the straight side as shown in the drawing.

a Go outside with your group. Hold your anemometer by the stick with the straight side upwards, in the direction in which the wind is blowing, so that the string with the table tennis ball can move along the surface of the card semicircle.

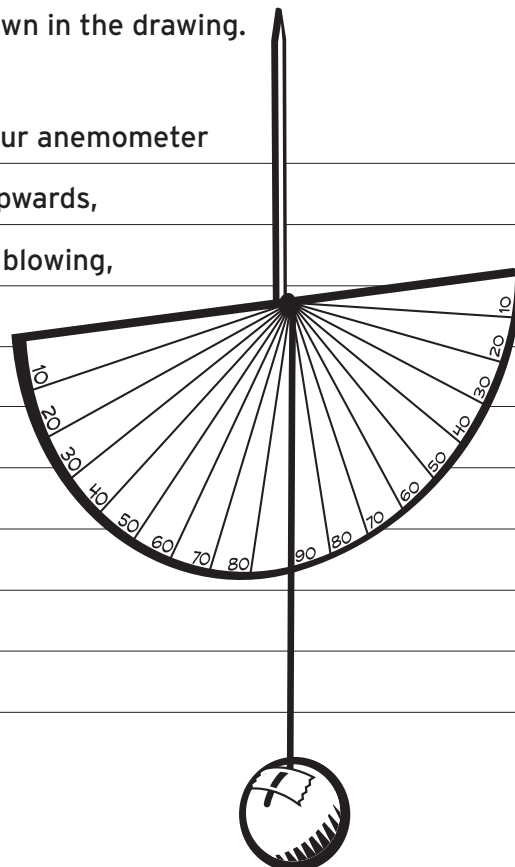



What happens to the table tennis ball?

b Read the number shown by the thread on the semicircle.

c Look up this number in the table below.

What wind force and wind speed does it show?

Wind force _____

Wind speed _____

Angle of string	90	80	70	60	50	40	30	20	10
Wind force (Bft)	0	3	3	4	5	5	6	7	7
Wind speed (km/h)	0	13	19	24	29	34	41	52	52
Description	Calm	Gentle breeze	Gentle breeze	Gentle breeze	Fresh breeze	Fresh breeze	Strong breeze	High wind	High wind

A storm is wind force 10 (100 km/h), a hurricane is wind force 12 (over 119 km/h).

d Why are there measuring lines on both sides of the middle line?

e Now answer the research question: *What is the wind speed today?*

f Is your answer the same as you wrote in Question 1b?

3 The weather journal



You are going to make a page about the anemometer for the weather journal.

For this you will need to answer the following questions.

Use books or the internet to find any extra information you need.

How does an anemometer work?

- What is the wind force on other planets in our solar system?
- Which planet has the most powerful winds and which planet has the least powerful winds?

